



Installation and Operation Manual

50-80kw

Pixel Solar Inverter



Contents

| | |
|--|----|
| 1. Introduction | 3 |
| 1.1 Product Description | 3 |
| 1.2 Unpacking inspection..... | 4 |
| 1.3 Packaging | 4 |
| 1.4 Optional Packaging | 5 |
| 1.5 Inverter Storage | 6 |
| 2. Safety Instructions | 7 |
| 2.1 Safety Symbols | 7 |
| 2.2 General Safety Instructions | 7 |
| 2.3 Notice For Use..... | 8 |
| 3. Overview | 9 |
| 3.1 Front Panel Display | 9 |
| 3.2 LED Status Indicator Lights | 9 |
| 3.3 Keypad | 10 |
| 3.4 LCD | 10 |
| 4. Installation | 11 |
| 4.1 Select Location for the Inverter | 11 |
| 4.2 Mounting the Inverter..... | 13 |
| 4.3 Electrical Connections | 15 |
| 4.3.1 Connect PV side of inverter | 15 |
| 4.3.2 Connect grid side of inverter | 18 |
| 4.3.3 External ground connection | 20 |
| 4.3.4 Max. overcurrent protection device (OCPD)..... | 21 |
| 4.3.5 Inverter monitoring connection | 22 |
| 4.3.6 CT connections (optional) | 23 |
| 4.3.7 DRED port connections(optional)..... | 24 |
| 5. Start & Stop | 25 |
| 5.1 Start the Inverter | 25 |
| 5.2 Stop the Inverter | 25 |

Contents

| | |
|------------------------------|----|
| 6.LCD Operation Menu..... | 27 |
| 6.1 Initialization..... | 27 |
| 6.2 Major cycle menuon | 27 |
| 6.3 User interface..... | 29 |
| 6.4 Setting..... | 29 |
| 6.5 Inquiry..... | 38 |
| 6.6 Statistics..... | 40 |
| 7.Maintenance | 42 |
| 8.Trouble shooting | 43 |

01 Introduction

1.1 Product Description

The new generation of household three-phase series photovoltaic grid connected inverter converts the sun into electric energy through the inverter device, which is used by the power users. It adopts a new design and integrates various functional devices to adapt to various complex installation environments.

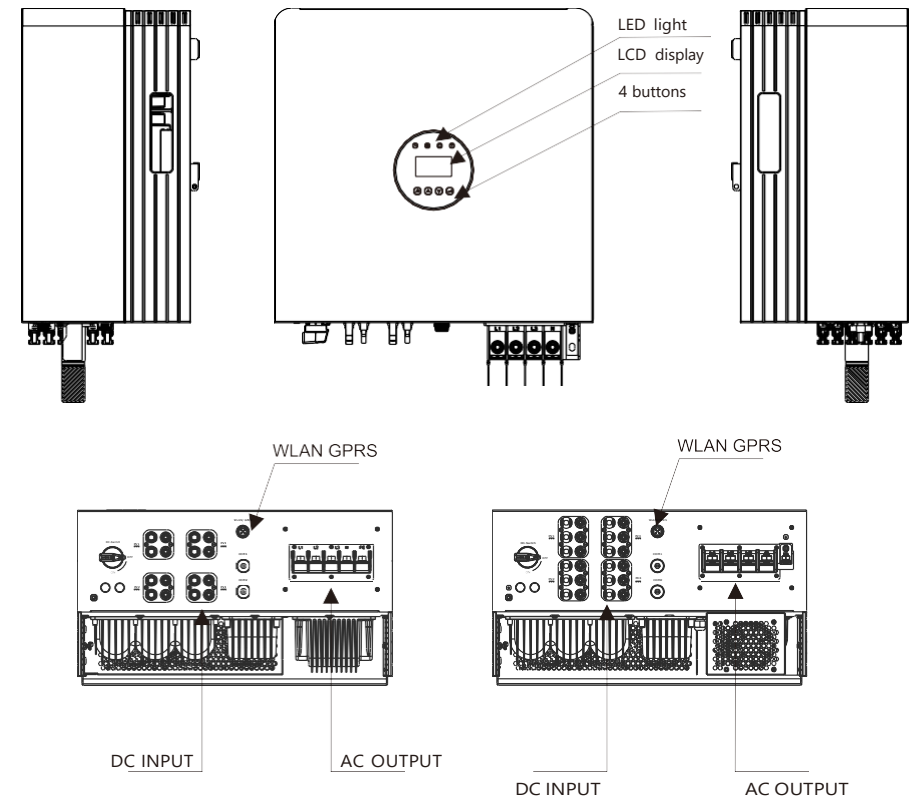

▲ Figure 1 Bottom side view

| Object | Description | DVC class | Object | Description | DVC class |
|--------|-----------------|-----------|--------|-------------|-----------|
| 1 | PV1,PV2,PV3,PV4 | DVC C | 2 | COM2(CT) | DVC A |
| 3 | WLAN GPRS | DVC A | 4 | AC | DVC A |

1.2 Unpacking Inspection

Before opening the inverter package, please check whether the outer package is damaged.
After opening the package, please check whether the inverter appearance is damaged or lack of accessories. The placement of accessories is as follows:

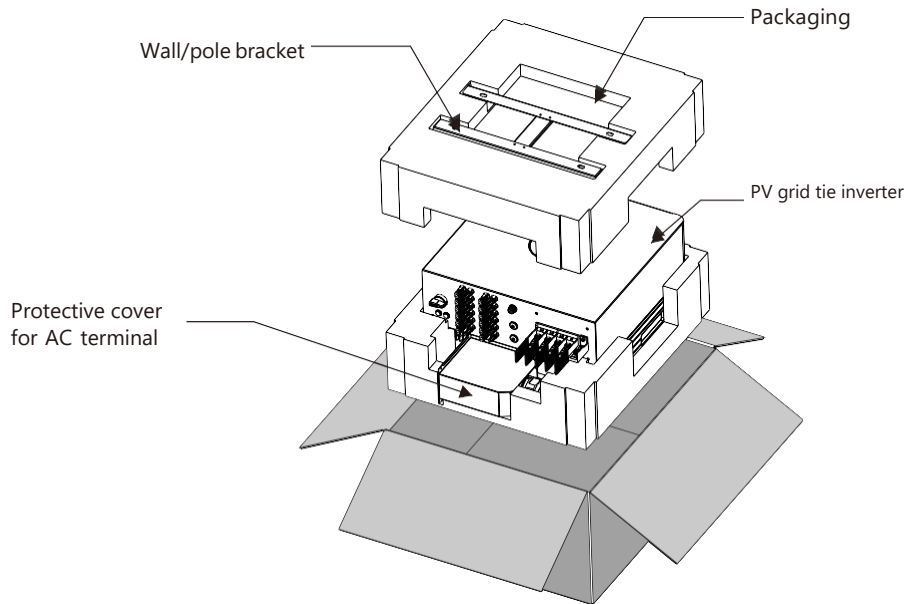

1.3 Packaging

When you receive the inverter, ensure that all the parts listed below are included:

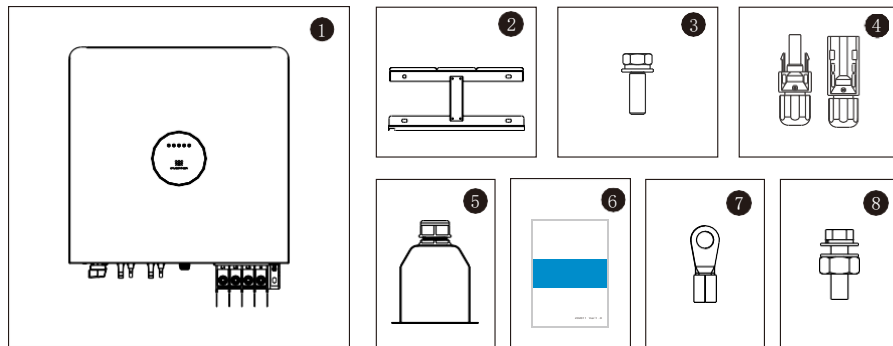

| Part # | Description | Model | Number |
|--------|----------------------------------|---------|--------|
| 1 | PV grid tie inverter | | 1 |
| 2 | Wall/pole bracket | | 1 |
| 3 | Locking screws | | 6 |
| 4 | PV connection terminal (+,-) | 40K~60K | 8 |
| | | 70~80K | 12 |
| 5 | Protective cover for AC terminal | | 1 |
| 6 | Manual | | 1 |
| 7 | OT terminal | | 6 |
| 8 | Combination screw | | 4 |

1.4 Optional Packaging

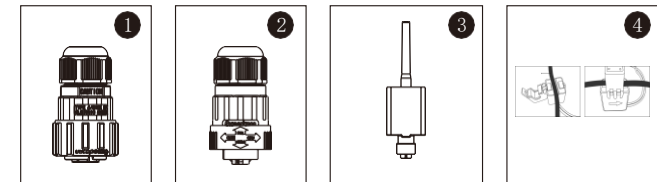

| Part # | Description | Number |
|--------|---------------------|--------|
| 1 | DRM connector | 1 |
| 2 | Meter 485 connector | 1 |
| 3 | WiFi/GPRS Stick | 1 |
| 4 | 1xCT and com cable | 1 |

1.5 Inverter Storage

Proper storage is required if the inverter is not installed immediately.

- Store the inverter in the original packing case.
- The storage temperature must be always between -40°C and $+70^{\circ}\text{C}$, and the storage relative humidity must be always between 0 and 95%, non-condensing.
- In case of stacking storage, the number of stacking layers should never exceed the limit marked on the outer side of the packing case.



- The packing case should be upright.
- If the inverter has been stored more than half a year, the qualified personnel should thoroughly check and test it before using.

02 Safety Instructions

Improper use may result in potential electric shock hazards or burns. This manual contains important instructions that should be followed during installation and maintenance. Please read these instructions carefully before use and keep them for future reference.

Contact the nearest hazardous waste disposal station when the products or components are discarded.

2.1 Safety Symbols

Safety symbols used in this manual, which highlight potential safety risks and important safety information, are listed as follows:

 **WARNING:** WARNING symbol indicates important safety instructions, which if not correctly followed, could result in serious injury or death.

 **NOTE:** NOTE symbol indicates important safety instructions, which if not correctly followed, could result in some damage or the destruction of the inverter.

 **CAUTION:** CAUTION, RISK OF ELECTRIC SHOCK symbol indicates important safety instructions, which if not correctly followed, could result in electric shock.



 **CAUTION:** CAUTION, HOT SURFACE symbol indicates safety instructions, which if not correctly followed, could result in burns.

2.2 General Safety Instructions

 **WARNING:** Only devices in compliance with SELV may be connected to the RS485 and USB interfaces.

 **WARNING:** Please don't connect PV array positive(+) or negative(-) to ground, it could cause serious damage to the inverter.

 **WARNING:** Electrical installations must be done in accordance with the local and national electrical safety standards.

  **WARNING:** Do not touch any inner live parts until 5 minutes after disconnection from the utility grid and the PV input.

WARNING:



To reduce the risk of fire, over-current protective devices (OCPD) are required for circuits connected to the Inverter. The DC OCPD shall be installed per local requirements. All photovoltaic source and output circuit conductors shall have disconnects that comply with the NEC Article 690, Part II.

CAUTION:



Risk of electric shock. Do not remove cover. There is no user serviceable parts inside. Refer servicing to qualified and accredited service technicians.

CAUTION:



The PV array (Solar panels) supplies a DC voltage when they are exposed to sunlight.

CAUTION:



Risk of electric shock from energy stored in capacitors of the Inverter. Do not remove cover for 5 minutes after disconnecting all power sources(service technician only). Warranty may be voided if the cover is removed without unauthorized. If the equipment is used in a manner not specified by the manufacturer, the protection provided by the equipment may be impaired.

CAUTION:



The surface temperature of the inverter can reach up to 75°C (167 F). To avoid risk of burns, do not touch the surface of the inverter while it's operating. Inverter must be installed out of the reach of children.



PV module used with inverter must have an IEC 61730 Class A rating.

CAUTION:



If the machine is configured with PID function, the panel is charged at night.

2.3 Notice For Use

The inverter has been constructed according to the applicable safety and technical guidelines. Use the inverter in installations that meet the following specifications only:

1. Permanent installation is required.
2. The electrical installation must meet all the applicable regulations and standards.
3. The inverter must be installed according to the instructions stated in this manual.
4. The inverter must be installed according to the correct technical specifications.
5. To startup the inverter, the Grid Supply Main Switch (AC) must be switched on, before the solar panel's DC isolator shall be switched on. To stop the inverter, the Grid Supply Main Switch (AC) must be switched off before the solar panel's DC isolator shall be switched off.

03

Over view

3.1 Front Panel Display

LCD display is Optional.

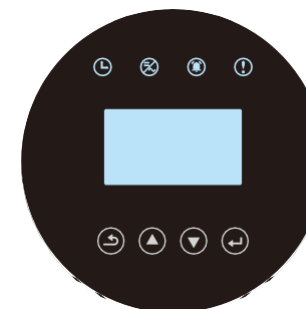

▲ Figure 3.1 Front Panel Display

3.2 LED Status Indicator Light

The LED status indicator can display red and green. When the indicator light is on, it indicates that there is power. When the indicator light is red, it indicates the alarm state; when the indicator light is green, it indicates the operation state.

| Light | Status | Description |
|-------|---------|--|
| | ON | Checking: The device is checking. |
| | ON | Generating: The device is generating the power. |
| | twinkle | Generating: flashing indicates that the inverter is being connected to the power grid. |
| | twinkle | Alarm: the inverter has an alarm signal. |
| | ON | Fault: A fault occurs and the device is not generating. |

▲Table 3.1 status indicator

3.3 Keypad (Optional)

There are four keys in the front panel of the Inverter from left to right: ESC, UP, DOWN and ENTER keys. The keypad is used for:

- Scrolling through the displayed options (the UP and DOWN keys);
- Access to modify the adjustable settings (the ESC and ENTER keys).

3.4 LCD

The four-line Liquid Crystal Display (LCD) is located on the front panel of the Inverter, which shows the following information:

- Inverter operation status and data;
- Service messages for operator;
- Alarm messages and fault indications.

You can also get information via WiFi / GPRS.

04 Installation

4.1 Select a Location for the Inverter

To select a location for the inverter, the following criteria should be considered:

- Do not install in small closed spaces where air can not circulate freely. To avoid over heating, always make sure the flow of air around the inverter is not blocked.
- Exposure to direct sunlight will increase the operational temperature of the inverter and may cause output power limiting. Company recommends inverter installed to avoid direct sunlight or raining.
- To avoid overheating ambient air temperature must be considered when choosing the inverter installation location. Company recommends using a sun shade minimizing direct sunlight when the ambient air temperature around the unit exceeds 104°F/40°C.



▲ Figure4.1 Recommended Installation locations

- Install on a wall or strong structure capable of bearing the weight.
- Install vertically with a maximum incline of $\pm 5^\circ$. If the mounted inverter is tilted to an angle greater than the maximum noted, heat dissipation can be inhibited, and may result in less than expected output power.
- When 1 or more inverters are installed in one location, a minimum 300mm clearance should be kept between each inverter or other object (if a canopy is added, a distance of 500mm must also be kept, it is necessary to install the canopy first and then fix the inverter to avoid the blocking of the fan caused by the cement debris falling during drilling). The bottom of the inverter should be 500mm clearance to the ground.

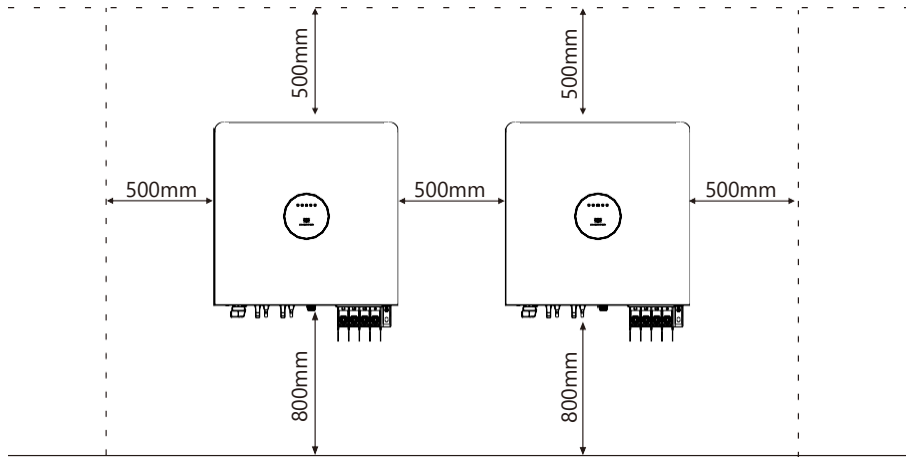

▲ Figure 4.2 Inverter Mounting clearance

- Visibility of the LED status indicator lights and the LCD located at the front panel of the inverter should be considered.
- Adequate ventilation must be provided if the inverter is to be installed in a confined space.



NOTE:

Nothing should be stored on or placed against the inverter. It is not allowed to lay the machine horizontally for a long time, which will affect the heat dissipation.

4.2 Mounting the Inverter

Dimensions of wall bracket:

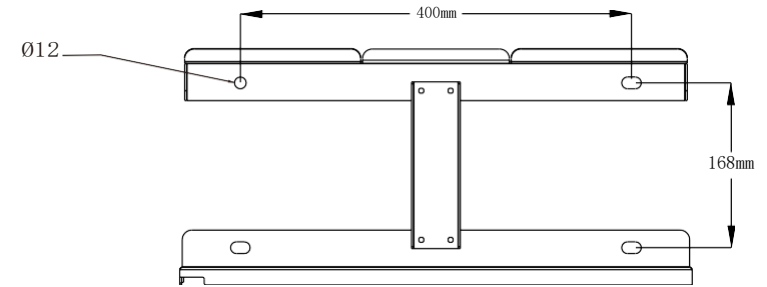

▲ Figure 4.3 Inverter wall mounting

The inverter shall be mounted vertically. The steps to mount the inverter are listed below:

1. According to Figure 4.2, select the bracket mounting height. The inverter standard with bolt group (including nut, flat gasket, spring washer) before delivery. To make the inverter can be installed to various metal holder. Use $\text{Ø}12$ driller kit to drill installation holes on the metal holder according to the hole position of the rack. Then fix the rack to metal holder by using bolt group.

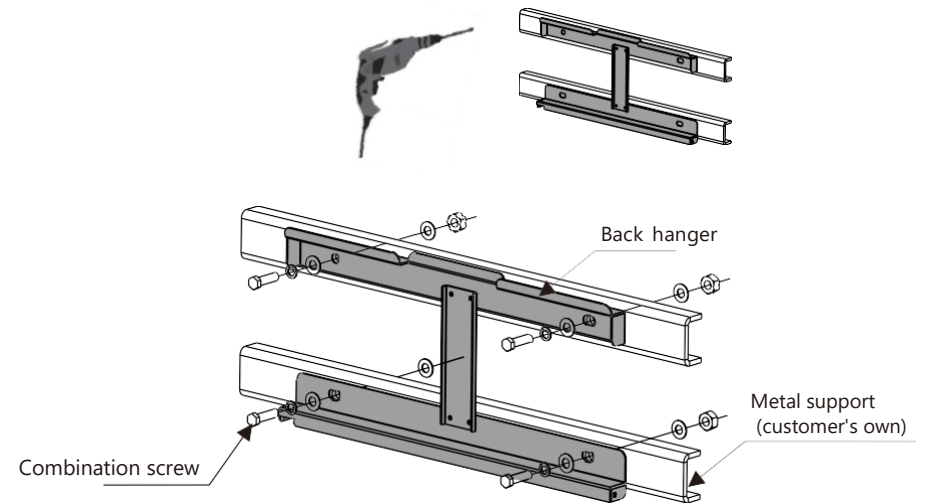

▲ Figure 4.4 Inverter wall mounting

2. Lift the inverter to the mounting plate and ensure that the mounting ears fit well with the grooves of the mounting plate. Check the sides to make sure they are in place.



WARNING:

The inverter must be mounted vertically.



NOTE:

In the process of machine handling, the bottom of the left and right plastic decorative parts should not be stressed to avoid damage to personnel and machinery caused by damage to plastic parts.

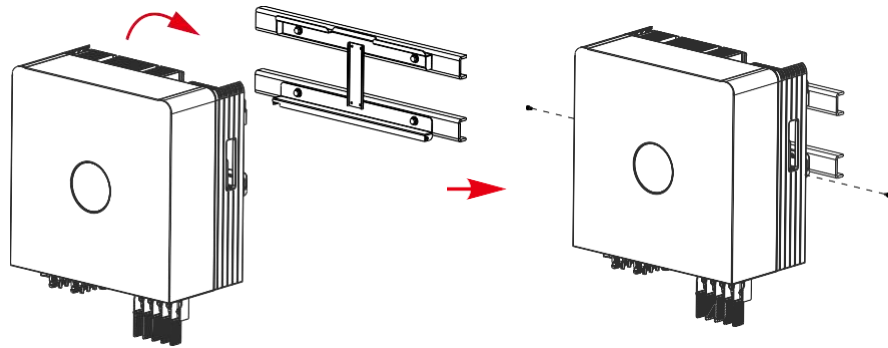
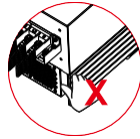

▲ Figure 4.5 Wall Mount Bracket

3. Use M4 screws in accessory to lock the inverter to the mount bracket.

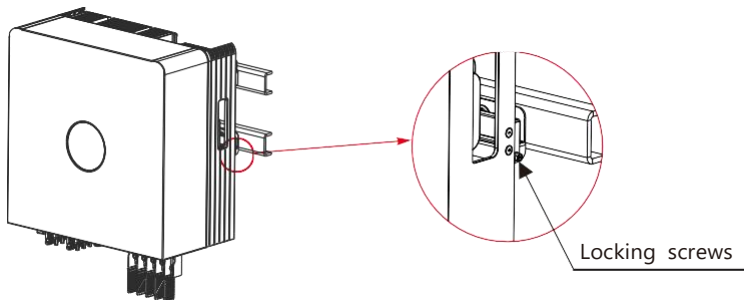

4.3 Electrical Connections

4.3.1 Connect PV side of inverter

The electrical connection of the inverter must follow the steps listed below:

1. Switch the Grid Supply Main Switch (AC) OFF.
2. Switch the DC Isolator OFF.
3. Assemble PV input connector to the Inverter.



Check whether the polarity of the connecting cable of the photovoltaic string is correct, and ensure that the open circuit voltage under any condition does not exceed the upper limit of the inverter input value of 1100V.



Please don't connect PV array positive or negative pole to the ground, it could cause serious damages to the inverter.



Before connection, please make sure the polarity of the output voltage of PV array matches the "PV+" and "PV-" symbols.

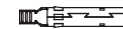
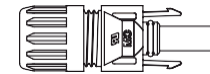

▲ Figure 4.6 PV+ Connector

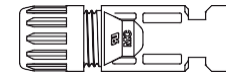

▲ Figure 4.7 PV- Connector

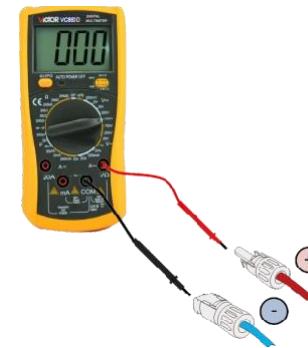

Check the positive and negative polarity of the PV strings, and connect the PV connectors to the right terminals. Serious damages to the inverter and connector over temperature may occur.

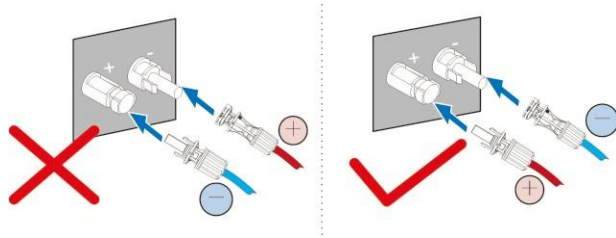

Please use approved DC cable for PV system.

| Cable type | Cross section | |
|--|--------------------|-------------------|
| | Range | Recommended value |
| Industry generic PV cable(model:PV1-F) | 4.0-6.0 (12-10AWG) | 4.0 (12AWG) |

▲ Table 4.1 DC cable

The steps to assemble the DC connectors are listed as follows:

1. Strip off the DC wire for about 7mm, Disassemble the connector cap nut.

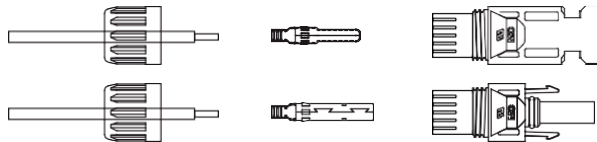

▲ Figure 4.8 Disassemble the Connector Cap nut

2. Insert the wire into the connector cap nut and contact pin.

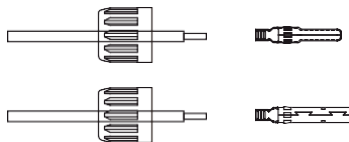

▲ Figure 4.9 Insert the Wire into the Connector Cap nut and contact pin

3. Crimp the contact pin to the wire using a proper wire crimper.

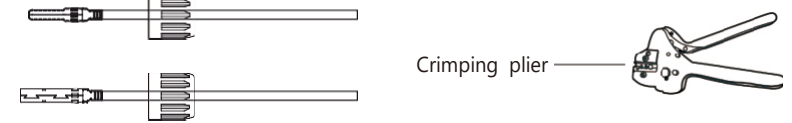

▲ Figure 4.10 Crimp the contact pin to the wire

4. Insert the contact pin to the top part of the connector and screw up the cap nut to the top part of the connector.

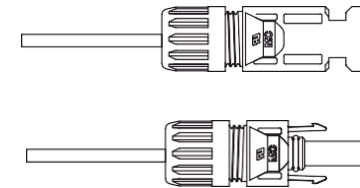

▲ Figure 4.11 Connector with Cap nut Screwed on

5. Then connect the DC connectors to the inverter. Small click will confirm connection.

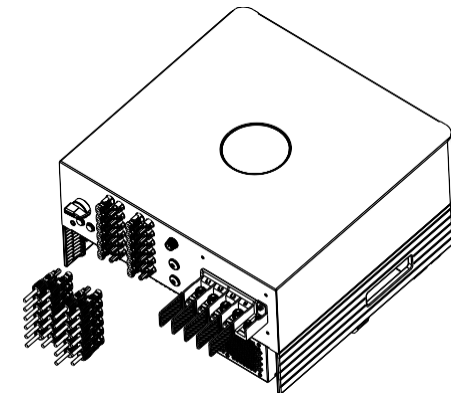

▲ Figure 4.12 Connect the DC Connectors to the Inverter

4.3.2 Connection of AC output

WARNING: There are "L1,L2,L3" "N" "PE" symbols marked inside the connector, the Line wire of grid must be connected to "L1,L2,L3" terminal; the Neutral wire of grid must be connected to "N" terminal; the Earth of grid must be connected to "PE"

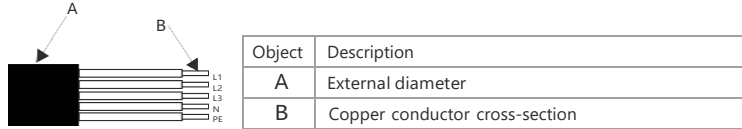
| Model | Cable outer diameter range | Cross section Range | Recommended cable section wire diameter |
|---------|----------------------------|----------------------|---|
| 40K~60K | φ24~φ44mm | 25-70mm ² | 35 mm ² |
| 70K~80K | φ30~φ50mm | 50-95mm ² | 50 mm ² |

▲ Table 4.2 AC cable

Connect grid side of inverter

- 1.First check the AC circuit breaker and disconnect the inverter and the grid
2. Use wire stripper to peel the outer surface of the cable for about 50 mm, and then peel off the wire skin of 5 wires, as shown in the figure below;

Step 1.Strip the protection layer and insulation layer by specific length,as described in the figure below.

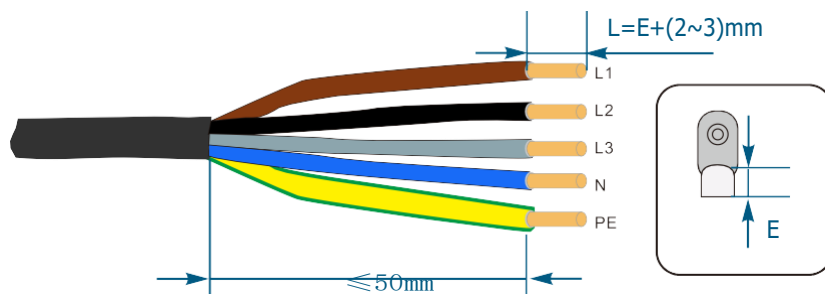

Step 2. Make the cable and crimp the OT terminal.

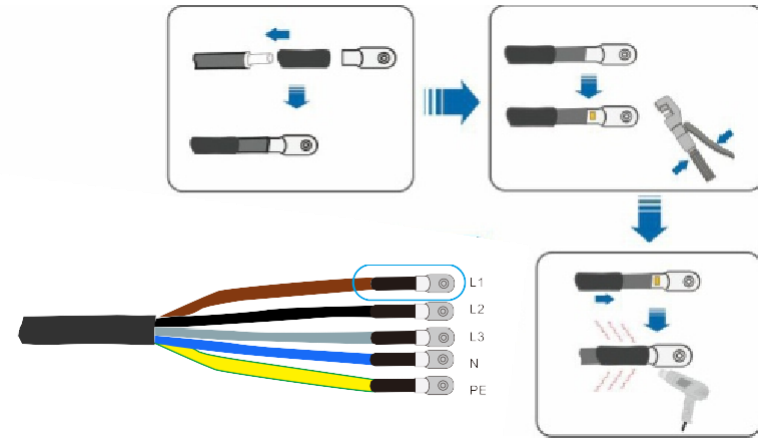

Step 3.Follow the instruction and secure the cable to corresponding terminals.

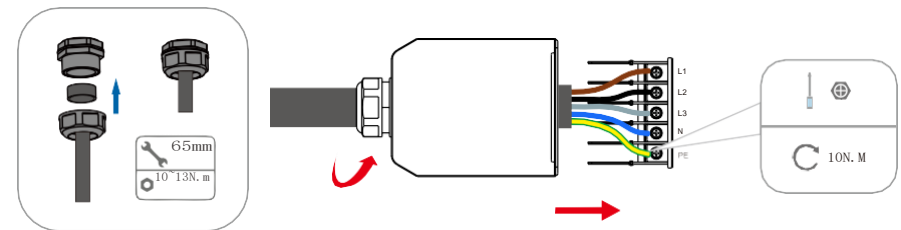

50~60K AC terminal wiring diagram

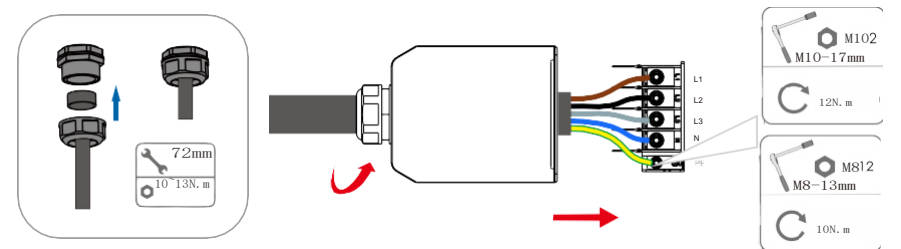

70~80K AC terminal wiring diagram

Step 4.Secure the junction box,fasten the buckle, and secure it with screw.

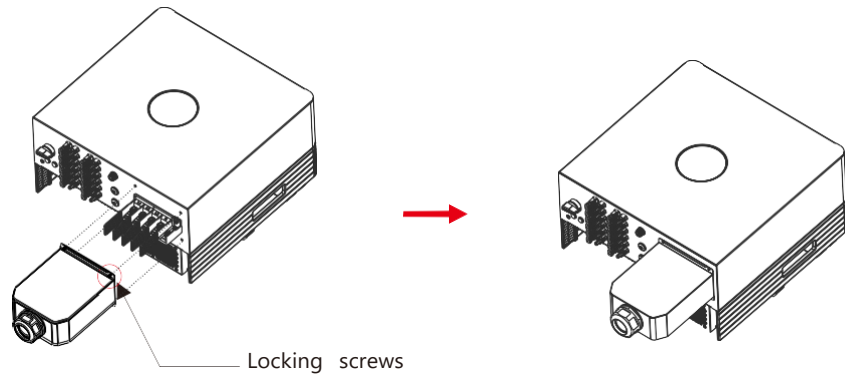

▲Figure 4.18 Connect the AC Connector to the Inverter

4.3.3 External ground connection

The external ground connection is located on the bottom side of the inverter. Prepare OT terminal, tighten the screw. The machine comes with it. Use appropriate tools to screw out the screw and crimp the lug to the terminal.

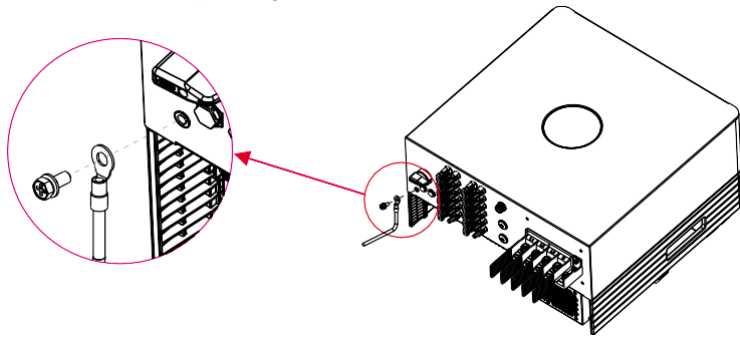

▲ Figure4.19 Connect the external grounding conductor



Note:

When earth fault occurs, the machine cannot be connected to the grid, the LED red light is on, and the LCD displays the fault code F07 until the fault is resolved.

4.3.4 Max, over current protection device (OCPD)

To protect the inverter's PV and AC grid connection conductors, Company recommends installing breakers that will protect against overcurrent. The following table defines OCPD ratings for the inverters.

| Inverter | Rated output voltage(V) | Rated output current (A) | Current for protection device (A) |
|----------|-------------------------|--------------------------|-----------------------------------|
| PXL40 | - | - | - |
| PXL50 | - | - | - |
| PXL60 | - | - | - |
| PXL70 | - | - | - |
| PXL75 | - | - | - |
| PXL80 | - | - | - |

▲Table 4.3 OCPD level of power grid

4.3.5 Inverter monitoring connection

The inverter can be monitored via Wi-Fi or GPRS. All communication devices are optional. For connection instructions, please refer to the Monitoring Device installation manuals.

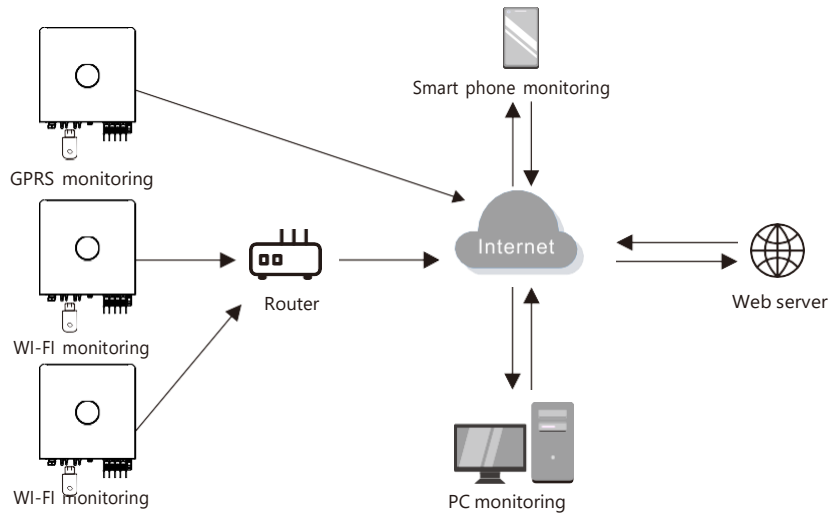

▲ Figure 4.20 Communication function

The inverter is equipped with standard RS485 and WLAN/GPRS communication ports, and the RS485 communication port is mainly used for the software upgrade, WLAN/GPRS communication port is for inverter wireless monitoring.

| Pin | Description | Pin | Description |
|-----|-------------|-----|-------------|
| 1 | VCC | 3 | 485A |
| 2 | GND | 4 | 485B |

▲ Table 4.5

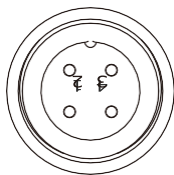

▲ Figure 4.21 Inverter WLAN/GPRS port

4.3.6 Meter connections(optional)

This inverter has integrated export limitation functionality. To use this function, a CT must be installed, if use the CT, please reference below picture. The CT should be fitted around the live conductor on the grid side of the main incoming consumer unit. Use the directional flow indication arrow on the CT to ensure it is fitted in the correct orientation. The arrow should be pointing towards the grid, not the load.

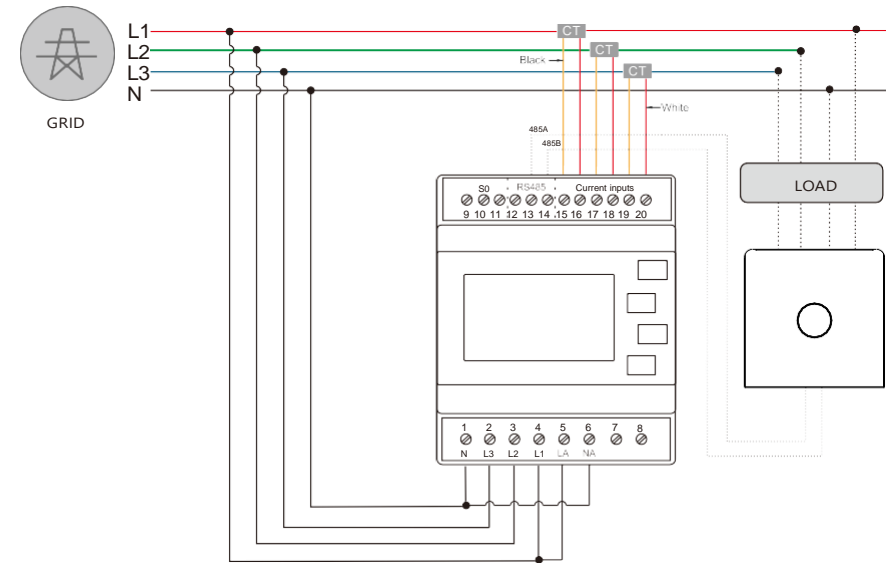

▲ Figure 4.22 Schematic diagram of connection between inverter and meter (Inverter on the right side of load)

| Pin | Description | Pin | Description |
|-----|-------------|-----|-------------------------|
| 1 | NC | 3 | 485A positive electrode |
| 2 | NC | 4 | 485B negative pole |

▲ Table 4.6



Please follow below figure to assemble CT connector.

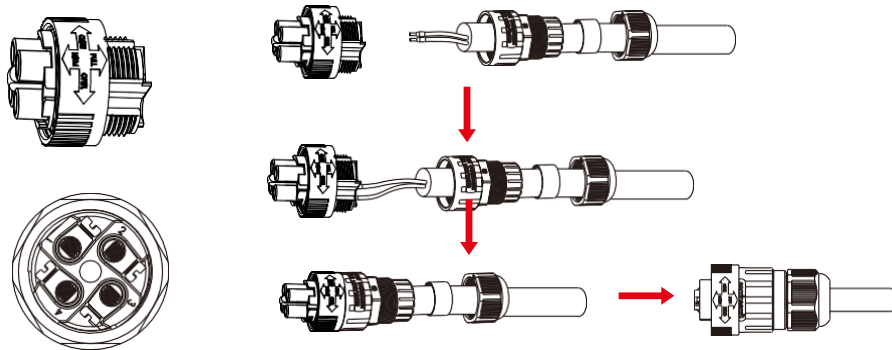

▲ Figure 4.23 CT connector

4.3.7 DRED port connections(optional)

DRED means demand response enable device. The AS/NZS 4777.2:2015 required inverter need to support demand response mode(DRM). This function is for inverter that comply with AS/NZS 4777.2:2015 standard. Inverter is fully comply with all DRM. A 6P terminal is used for DRM connection.

| Pin | Description | Pin | Description |
|-----|-------------|-----|-------------|
| 1 | DRM 0 | 4 | DRM 7 |
| 2 | DRM 5 | 5 | DRM 8 |
| 3 | DRM 6 | 6 | Com |

▲ Table 4.7

Please follow below figure to assemble DRM connector.

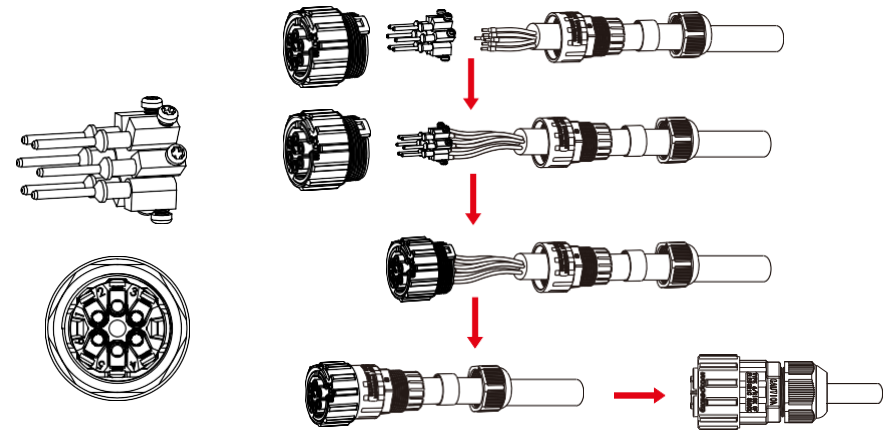

▲ Figure 4.24 DRM connector

05 Start&Stop

5.1 Start the Inverter

To start up the Inverter, it is important that the following steps are strictly followed:

1. Switch the grid supply main Switch (AC) ON first.
2. Switch the DC switch ON. If the voltage of PV arrays are higher than start up voltage, the inverter will turn on. The LED status indicator will light.
3. When both the DC and the AC sides supply to the inverter, it will be ready to generate power. Initially, the inverter will check both its internal parameters and the parameters of the AC grid, to ensure that they are within the acceptable limits. At the same time, the green LED will flash and the LCD displays the information of INITIALIZING.
4. After 60-300 seconds (depending on local requirement), the inverter will start to generate power. The green LED will be on continually and the LCD displays GENERATING.



WARNING:

When the photovoltaic array is exposed to light, it supplies a DC voltage to the PCE. Do not touch it. Do not touch the surface when the inverter is operating. It may be hot and cause burns.

5.2 Stop the Inverter

To stop the Inverter, the following steps must be strictly followed:

1. Switch the Supply Main Switch (AC) OFF.
2. Wait 30 seconds. Switch the DC Switch OFF. All the LEDs of the inverter will be off in one minute.

06 LCD Operation Menu

6.1 Initialization

| Interface | Explanation |
|--|---|
| <div style="border: 1px solid black; padding: 5px; width: fit-content; margin: auto;"> Initializing... Please Wait! </div> | After starting-up of inverter, LCD will firstly enter this interface, and deliver parameters required by operation of the machine to DSP. |

6.2 Major cycle menu-on

After initialization, LCD will enter a major cycle menu to display running information of the inverter in a circulating mode, including 10 interfaces for network voltage, frequency of electric network, etc. Time for automatic switch-over between interfaces is 3 seconds, also the interfaces can be switched manually by pressing UP or DOWN buttons, if you want to fix at a certain interface, press ENTER to lock this interface, after successful locking, a lock icon will occur at upper right corner of this interface, press ENTER button again, this interface will be unlocked, and the menu will continue to display in a circulating mode.

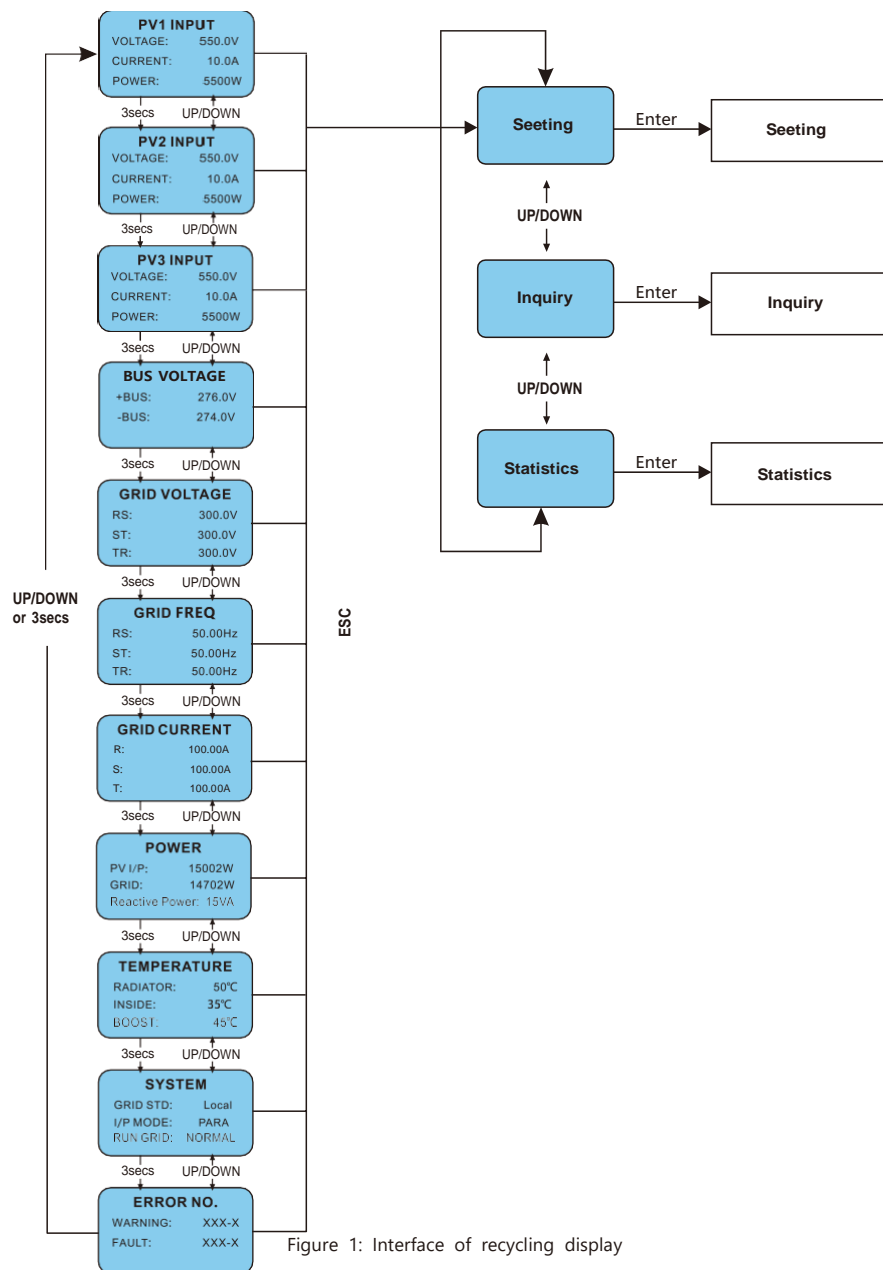

Figure 1: Interface of recycling display

When the menu is in an automatic cycling display mode, if error (fault) or warning alarm occurs, it will skip into system interface immediately and lock to it, and this will make convenience for the user to determine its cause based on codes on the interface. After disappearing of error (fault) or warning alarm, the menu will return to automatic circulating mode. Press ESC button to exit major circulating menu interface and enter user interface (refer to 6.3).

6.3 User interface

| Interface | Explanation |
|---|---|
| <pre> -----USER----- ->1:Setting 2:Inquire 3:Statistics </pre> | Select corresponding options by pressing UP or DOWN button, enter "setting", "inquiry" and "statistics" menus by pressing ENTER button. Press ESC to return major circulating menu. |

6.4 Setting

| Interface | Explanation |
|---|--|
| <pre> ---PASSWORD--- Input:XXXXX </pre> | After entering into the setup interface, the system will prompt to input password, the default password is "0000", and this password can be altered Password setting menu (refer to 6.4.12); press UP/DOWN to increase or decrease the input figure, press ENTER button to move the cursor backwards, press ESC button to move the cursor forward. |

| | |
|--|---|
| <pre> -----SETUP----- ->1: INPUT MODE 2: GRID STD 3: REMOTE CTRL </pre> | After successful input of password, it will enter setting option interface. Press UP/DOWN to move corresponding options, and enter the selected menu by pressing ENTER button; press ESC button to return back the user interface (refer to 6.3), there are 15 options in total, including input mode, grid std, remote ctrl, run setting, 485 address, baud rate, protocol, language, backlight, date/time, clear rec, password ,maintenance, fctry reset,array detec. |
|--|---|

6.4.1 Input mode

| Interface | Explanation |
|---|---|
| <pre>--- INPUT MODE --- →1:INDEPENDENT 2:PARALLEL</pre> | <p>Press UP/DOWN button to move corresponding option. Then confirm the selected option and enter interface of please restart (refer to 6.4.4.11) by pressing ENTER button. Press ESC button to cancel choice and return back setup interface (refer to 6.4). Default option is independent.</p> |

6.4.2 Standard for electric network

| Interface | Explanation |
|---|---|
| <pre>----GRID STD---- →1:China 2:Germany 3:Australia 4:Italy 5:Spain 6:U.K.</pre> | <p>Press UP/DOWN button to move corresponding options, including China, Germany, Australia, Italy, Spain, U.K; with 16 kinds in total. Then confirm the selected option and enter interface of please restart (refer to 6.4.4.11) by pressing ENTER button. Press ESC button to cancel choice and return back setup interface (refer to 6.4).</p> |

6.4.3 Remote CTRL

| Interface | Explanation |
|---|---|
| <pre>----REMOTE CTRL ---- →1:DISABLE 2:ENABLE</pre> | <p>Press UP/DOWN button to move corresponding options. Then confirm the selected option and return back setup interface (refer to 6.4) by pressing ENTER button. Press ESC to cancel choice and return back setup interface (refer to 6.4). Default option is disability.</p> |

6.4.4 Working parameters

| Interface | Explanation |
|---|--|
| <pre>-- RUN SETTING-- →1: VPV-START 2: DELAY-START 3: VAC-MIN</pre> | <p>Press UP/DOWN button to move corresponding options, press ENTER to enter into the selected menu; return back setup interface (refer to 6.4) by pressing ESC, there are 10 options in total, including VPV-START,DELAY-START ,VAC-MIN ,VAC-MAX , FAC-MIN, FAC-MAX, ACTIVE POWER, REACT POWER, FREQ POWER and V LOAD.</p> |

6.4.4.1 Starting-up voltage

| Interface | Explanation |
|---|--|
| <pre>---START-UP VOLT--- INPUT:200V UNIT: V</pre> | <p>Press UP/DOWN to increase or decrease the input figure, move the cursor backwards and confirm completion of input as well as enter into interface of please restart (refer to 6.4.4.11) by pressing ENTER button, press ESC to move the cursor frontward and return back working interface (refer to 6.4.4); the input figure is 200, default is 200.</p> |

6.4.4.2 Starting-up delay time

| Interface | Explanation |
|--|--|
| <pre>-- START-UP DELAY-- INPUT: 60 UNIT: SEC</pre> | <p>Press UP/DOWN to increase or decrease the input figure, confirm input and enter into interface of please restart (refer to 6.4.4.11) by pressing ENTER button; press ESC to 4 cancel input and return back working interface (refer to 6.4.4), input figure is between 60 and 300. This parameter is changed by grid standards.</p> |

6.4.4.3 Low voltage of electric network

| Interface | Explanation |
|---|---|
| <pre>--GRID VOLT LOW-- INPUT: 450 UNIT: V</pre> | <p>Press UP/DOWN to increase or decrease the input figure, confirm input and enter into interface of please restart (refer to 6.4.4.11) by pressing ENTER button; press ESC to cancel input and return back working interface (refer to 6.4.4), input figure is between 450 and 490. This parameter is changed by grid standards.</p> |

6.4.4.4 High voltage of electric network

| Interface | Explanation |
|--|---|
| <pre>-- GRID VOLT HIGH -- INPUT:550 UNIT:V</pre> | <p>Press UP/DOWN to increase or decrease the input figure, confirm input and enter into interface of please restart (refer to 6.4.4.11) by pressing ENTER button; press ESC to cancel input and return back working interface (refer to 6.4.4), the input figure is between 510 and 550. This parameter is changed by grid standards.</p> |

6.4.4.5 Low frequency of electric network

| Interface | Explanation |
|--|---|
| <pre>-- GRID FREQ LOW-- INPUT: 49.5 UNIT: Hz</pre> | <p>Press UP/DOWN to increase or decrease the input figure, confirm input and enter into interface of please restart (refer to 6.4.4.11) by pressing ENTER button; press ESC to cancel input and return back working interface (refer to 6.4.4), the input figure is between 45.0 and 49.8. This parameter is changed by grid standards.</p> |

6.4.4.6 High frequency of electric network

| Interface | Explanation |
|---|---|
| <pre>-- GRID FREQ HIGH-- INPUT:50.5 UNIT:Hz</pre> | <p>Press UP/DOWN to increase or decrease the input figure, confirm input and enter into interface of please restart (refer to 6.4.4.11) by pressing ENTER button; press ESC to cancel input and return back working interface (refer to 6.4.4), the input figure is between 50.2 and 55. This parameter is changed by grid standards.</p> |

6.4.4.6 Active power

| Interface | Explanation |
|---|--|
| <pre>-- ACTIVE POWER -- →1:PERCENT SET 2:VALUE SET</pre> | <p>Press UP/DOWN to move corresponding options, and enter the selected menu by pressing ENTER button; press ESC button to return back working interface (refer to 6.4.4)</p> |

6.4.4.7.1 Power limit

| Interface | Explanation |
|---|--|
| <pre>----POWER LIMIT---- INPUT: 019 %</pre> | <p>Press UP/DOWN to increase or decrease the input figure, confirm input and enter into interface of Active power (refer to 6.4.4.7) by pressing ENTER button; press ESC to cancel input and return back Active power (refer to 6.4.4.7), the input figure is between 0 and 100,100% corresponds to 1.1 times of rated power output.</p> |

6.4.4.7.2 Power Value

| Interface | Explanation |
|--|---|
| <pre>-- POWER VALUE -- INPUT: KW</pre> | <p>Press UP/DOWN to increase or decrease the input figure, confirm input and enter into interface of Active power (refer to 6.4.4.7) by pressing ENTER button; press ESC to cancel input and return back Active power (refer to 6.4.4.7), the input figure is between 0 and Pmax.</p> |

6.4.4.8 Reactive power

| Interface | Explanation |
|--|--|
| <pre>-- RE-POWER SET -- →1:RE-POWER CTL 2:POWER FACTOR 3:PERCENT SET</pre> | <p>Press UP/DOWN to move corresponding options, and enter the selected menu by pressing ENTER button; press ESC button to return back working interface (refer to 6.4.4)</p> |

6.4.4.8.1 RE-POWER CTL

| Interface | Explanation |
|---|---|
| <pre>--RE-POWER CTL-- →1:POWER FACTOR 2:REACT POWER 3:QV WAVE</pre> | <p>Press UP/DOWN button to move corresponding options. And confirm selected option and return back the Reactive power by pressing ENTER button (refer to 6.4.4.8), press ESC button to cancel choice and return back Reactive power (refer to 6.4.4.8);</p> |

6.4.4.8.2 Power factor

| Interface | Explanation |
|---|--|
| <pre>--POWER FACTOR-- INPUT:0.000</pre> | <p>Press UP/DOWN to increase or decrease the input figure, confirm input and return back Reactive power (refer to 6.4.4.8) by pressing ENTER button, press ESC button to cancel input and return back Reactive power (refer to 6.4.4.8); The default value is 1, and the range can be set from 0.8 to 1.2, where 0.8 means lag 0.8 and 1.2 means lead 0.8.</p> |

6.4.4.8.3 Reactive power

| Interface | Explanation |
|---------------------------------|---|
| -REACTIVE POWER- INPUT: -26% | Press UP/DOWN to increase or decrease the input figure, confirm input and return back Reactive power (refer to 6.4.4.8) by pressing ENTER button, press ESC button to cancel input and return back Reactive power (refer to 6.4.4.8); the input numerical value is between -60 and +60. |

6.4.4.9 Over frequency derating

| Interface | Explanation |
|--|---|
| ----FREQ POWER---- →1:FUNC ENB 2:THRESHOLD | Press UP/DOWN button to move corresponding options, press ENTER to enter into the selected menu; return back working interface (refer to 6.4.4) by pressing ESC, there are 2 options in total, including function enable and frequency threshold. |

6.4.4.9.1 Over frequency derating enable

| Interface | Explanation |
|--|---|
| --FREQ POWER-- →1:ENABLE 2:DISABLE | Press UP/DOWN button to move corresponding options, press ENTER to enter into the Over frequency derating interface (refer to 6.4.4.9); return back Over frequency derating interface (refer to 6.4.4.9) by pressing ESC, there are 2 options in total, including enable and disable. |

6.4.4.9.2 Frequency threshold

| Interface | Explanation |
|--|---|
| ----THRESHOLD---- INPUT: 65.0 UNIT: Hz | Press UP/DOWN to increase or decrease the input figure, confirm input and enter into interface of Over frequency derating interface (refer to 6.4.4.9) by pressing ENTER button; press ESC to cancel input and return back Over frequency derating interface (refer to 6.4.4.9).the input numerical value is between 50.2 and 65.0. |

6.4.4.10 Over voltage derating

| Interface | Explanation |
|--|---|
| --- V LOAD --- →1:ENABLE 2:DISABLE | Press UP/DOWN button to move corresponding options, press ENTER to enter into the working interface (refer to 6.4.4); return back working interface (refer to 6.4.4) by pressing ESC, there are 2 options in total, including enable and disable. Overvoltage threshold setting, 242 ~ 270V. |

6.4.4.11 Please restart

| Interface | Explanation |
|-----------------|---|
| Please Restart! | A prompt that it is required to start the machine once again, so that the setup relevant to working will be effective, and it will return back working interface (refer to 6.4.4) within 2 seconds. |

6.4.5 485 address

| Interface | Explanation |
|------------------------------|--|
| ---485 ADDRESS--- INPUT:1 | Press UP/DOWN to increase or decrease the input figure, confirm input and return back setup interface (refer to 6.4) by pressing ENTER button, press ESC button to cancel input and return back setup interface (refer to 6.4); the input numerical value is between 1 and 64. |

6.4.6 485 baudrate

| Interface | Explanation |
|---|---|
| -----SELECT----- →1:2400 bps 2:4800 bps 3:9600 bps | Press UP/DOWN button to move corresponding options. And confirm selected option and return back the setup interface by pressing ENTER button (refer to 6.4), press ESC button to cancel choice and return back setup interface (refer to 6.4); options include 2400, 4800, 9600 and 19200, with 4 in total,Default is 9600. |

6.4.7 485 protocol

| Interface | Explanation |
|--|---|
| <pre>----SELECT---- →1: MODBUS 2:SOLAR RTU</pre> | <p>Press UP/DOWN button to move corresponding options. And confirm selected option and return back the setup interface by pressing ENTER button (refer to 6.4), press ESC button to cancel choice and return back setup interface (refer to 6.4);</p> |

6.4.8 Display language

| Interface | Explanation |
|---|--|
| <pre>---Display language--- →1:中文 2:ENGLISH 3:DEUTSCH</pre> | <p>Press UP/DOWN button to move corresponding options. And confirm selected option and enter into the setup interface (refer to 6.4) by pressing ENTER button, press ESC button to cancel choice and return back setup interface (refer to 6.4).</p> |

6.4.9 Input time

| Interface | Explanation |
|---|---|
| <pre>---LIGHT TIME--- INPUT: 20 UNIT: SEC</pre> | <p>Press UP/DOWN to increase or decrease the input figure, confirm input and return back setup interface (refer to 6.4) by pressing ENTER button, press ESC button to cancel input and return back setup interface (refer to 6.4); the input numerical value is between 20 and 120.</p> |

6.4.10 Date and time

| Interface | Explanation |
|---|--|
| <pre>-----DATE/TIME----- DATE:2000-01-01 TIME: 02:43:03 WEEK: 6</pre> | <p>Press UP/DOWN to increase or decrease the input figure; press ENTER button to move the cursor backwards, confirm input and return back setup interface (refer to 6.4); and move the cursor forward and return back setup interface (refer to 6.4) by pressing ESC button.</p> |

6.4.11 History clearing

| Interface | Explanation |
|---|--|
| <pre>--- DEL REC--- →1: CANCEL 2: CONFIRM</pre> | <p>Clear all records in inquiry/record menu (refer to). Press UP/DOWN button to move corresponding options, and confirm the selected option and enter into setup interface (refer to 6.4) by pressing ENTER; press ESC button to cancel option and return back setup interface (refer to 6.4).</p> |

6.4.12 Password setting

| Interface | Explanation |
|--|--|
| <pre>----- PASSWORD ----- OLD: XXXXX NEW: XXXXX CONFIRM: XXXXX</pre> | <p>This interface will be used to alter password when entering into the setup interface (refer to 6.4). Press UP/ DOWN to increase or decrease the input figure, press ENTER button to move the cursor backwards, confirm input and return back setup interface (refer to 6.4); and move the cursor forward and return back setup interface (refer to 6.4) by pressing ESC button.</p> |

6.4.13 Maintenance

| Interface | Explanation |
|---|---|
| <pre>-----PASSWORD----- INPUT:XXXXX</pre> | <p>This interface will be used for factory testing, and be protected by password.</p> |

6.4.14 Factory reset

| Interface | Explanation |
|--|---|
| <pre>-FACTORY RESET- →1: CANCEL 2: CONFIRM</pre> | <p>This interface will be used to reset inverter parameter to default. Press UP/DOWN button to move corresponding options, and confirm the selected option and enter into setup interface (refer to 6.4) by pressing ENTER; press ESC button to cancel option and return back setup interface (refer to 6.4).</p> |

6.4.15 Array detection

| Interface | Explanation |
|---|---|
| <pre>- ARRAY DETECT - →1:DETECT ENB 2:THRESHOLD</pre> | <p>Press UP/DOWN button to move corresponding options, and confirm the selected option and enter into setup interface (refer to 6.4) by pressing ENTER; press ESC button to cancel option and return back setup interface (refer to 6.4).</p> |

6.4.15.1 ARRAY

| Interface | Explanation |
|--|---|
| <pre>--ARRAY-- 1:ENABLE →2:DISABLE</pre> | <p>Press UP/DOWN button to move corresponding options. And confirm selected option and return back Array detection by pressing ENTER button (refer to 6.4.15), press ESC button to cancel choice and return back Array detection (refer to 6.4.15);</p> |

6.4.15.2 THRESHOLD

| Interface | Explanation |
|-----------------------------------|--|
| <pre>--THRESHOLD-- INPUT:8A</pre> | Press UP/DOWN to increase or decrease the input figure, confirm input and return back Array detection (refer to 6.4.15) by pressing ENTER button, press ESC button to cancel input and return back Array detection (refer to 6.4.15); the input numerical value is between 5 and 25. |

6.4.16 Three-phase system

| Interface | Explanation |
|--|--|
| <pre>--Three-phase system-- 1:3W+N+PE →2:3W+PE</pre> | According to the actual wiring mode ; Press UP/DOWN button to move corresponding options, and confirm the selected option and enter into setup interface (refer to 6.4) by pressing ENTER; press ESC button to cancel option and return back setup interface (refer to 6.4). |

6.5 Inquiry

| Interface | Explanation |
|--|--|
| <pre>-----INQUIRE----- →1: INV MODEL 2: MODEL NO 3: FIRMWARE 4: RECORD</pre> | Press UP/DOWN button to move the corresponding option, enter into the selected menu by pressing ENTER button; and return back the user interface (refer to 6.3) by pressing ESC button, there are 5 options in total, including INV MODEL, MODEL NO, FIRMWARE, RECORD And ERROR EVENT. |

| 6.5.1 Interface | Explanation |
|-------------------------------------|--|
| <pre>-----INVERTER----- XXXXX</pre> | This interface displays product Model of the inverter. UP/DOWN button is invalid, ENTER button is invalid; and press ESC button to return back the inquiry interface (refer to 6.5). |

| 6.5.2 Interface | Explanation |
|-----------------------------------|---|
| <pre>-----INVERTER----- SN:</pre> | This interface displays product series No. of the inverter. UP/DOWN button is invalid, ENTER button is invalid; and press ESC button to return back the inquiry interface (refer to 6.5). |

6.5.3 Firmware

| Interface | Explanation |
|---|--|
| <pre>-----FIRMWARE----- ARM VER: I- DSP VER: B-DSP VER:</pre> | This interface displays edition No. of firmware such as ARM and DSP in inverter. UP/DOWN button is invalid, ENTER button is invalid; and press ESC button to return back the inquiry interface (refer to 6.5). |

6.5.4 RECORD

| Interface | Explanation |
|---|---|
| <pre>-----REC(35)----- 1:F01-1 DATE: 2011-10-21 TIME: 16:35:26</pre> | This interface displays record and its occurring time, including two types of fault and warning alarm, its content will be described in codes, with total number of 500 at utmost, after exceeding this extent, the one with earliest time will be covered. Press UP/DOWN button to look over record backwards or frontward, and press ENTER to enter into explanation interface for corresponding record content, as shown in the following Figure. Press ESC to return back inquiry interface (refer to 6.5). |

| | |
|---|--|
| <pre>-----DETAIL----- Grid voltage High</pre> | This interface will be used to reset inverter parameter to default. Press UP/DOWN button to move corresponding options, and confirm the selected option and enter into setup interface (refer to 6.4) by pressing ENTER; press ESC button to cancel option and return back setup interface (refer to 6.4). |
|---|--|

| | |
|------------------------------|--|
| <pre>--- VALUE--- 285V</pre> | This interface is used for displaying the corresponding specific numerical value when the code generates. For example, producing error code for high voltage value of commercial power, and we can refer to the voltage value of cat that that in this interface. Some codes correspond no numerical values, and then these interfaces are blank. If the voltage value is 999.9, it means that the voltage and current of the power grid have a shock protection. UP/ DOWN button is invalid, and ENTER is also invalid; press ESC button to return back the last interface. |
|------------------------------|--|

6.5.5 ERROR EVENT

| Interface | Explanation |
|---|---|
| <pre>-----EVE(20)----- 1:F01-1 Date: 2011-10-21 Time: 16:35:26</pre> | Press UP/DOWN button to look over record backwards or frontward, and press ENTER to enter into explanation interface for corresponding record content, as shown in the following Figure. Press ESC to return back inquiry interface (refer to 6.5). |
| <pre>--EVE(1)-- +BUS: 350.0V -BUS: 350.0V RADIATOR: 50°C</pre> | Press UP/DOWN button to look over record backwards or frontward, press ESC button to return back the last interface. |

```
--EVE(1)--
RS: 0.00Hz
ST: 0.00Hz
TR: 0.00Hz
```

Press UP/DOWN button to look over record backwards or frontward, press ESC button to return back the last interface.

```
--EVE(1)--
RS: 0.00V
ST: 0.00V
TR: 0.00V
```

Press UP/DOWN button to look over record backwards or frontward, press ESC button to return back the last interface.

6.6 Statistics

| Interface | Explanation |
|---|---|
| <pre>---- STAT. ---- →1:TIME STAT. 2:CONNE.TIMES 3:PEAK POWER</pre> | <p>This interface is used to select various options for statistics. UP/DOWN button is used to move corresponding options, press ENTER button to enter the selected menu; and press ESC to return back the user interface (refer to 6.3), there are 8 options, including time, networking number, total, that day, that week, that month, that year, power peak.</p> |

| Interface | Explanation |
|---|---|
| <pre>----TIME---- RUN: 86 GRID: 56 UNIT: HOUR</pre> | <p>This interface displays operational time and generating duration of the inverter. UP/DOWN button is invalid, and ENTER is also invalid; press ESC button to return back statistics interface (refer to 6.6).</p> |

6.6.2 Times of paralleling in

| Interface | Explanation |
|--------------------------------------|--|
| <pre>--CONNE.TIMES-- TIMES: 45</pre> | <p>This interface displays times of paralleling in for the inverter. UP/ DOWN button is invalid, and ENTER is also invalid; press ESC button to return back statistics interface (refer to 6.6).</p> |

6.6.3 Power peak

| Interface | Explanation |
|---|--|
| <pre>----PEAK POWER---- HISTORY:10645 TODAY: 9600 UNIT: W</pre> | <p>This interface displays history power peak and today power peak of the inverter. UP/DOWN button is invalid, and ENTER is also invalid; press ESC button to return back statistics interface (refer to 6.6).</p> |

6.6.4 Generated energy of that day

| Interface | Explanation |
|--|--|
| <pre>----E-TODAY ---- NUM: 100 UNIT: KWH</pre> | <p>This interface displays generated energy of that day. Refresh after 24 o'clock, inverter time should be set in different time zones. UP/DOWN button is invalid, and ENTER is also invalid; press ESC button to return back statistics interface (refer to 6.6).</p> |

6.6.5 Generated energy of that week

| Interface | Explanation |
|--|---|
| <pre>----E-WEEK---- NUM: 700 UNIT: KWH</pre> | <p>This interface displays generated energy of that day. UP/DOWN button is invalid, and ENTER is also invalid; press ESC button to return back statistics interface (refer to 6.6).</p> |

6.6.6 Generated energy of that month

| Interface | Explanation |
|--|---|
| <pre>----E-MONTH---- NUM: 3000 UNIT: KWH</pre> | <p>This interface displays generated energy of that month. UP/DOWN button is invalid, and ENTER is also invalid; press ESC button to return back statistics interface (refer to 6.6).</p> |

6.6.7 Generated energy of that year

| Interface | Explanation |
|--|--|
| <pre>----E-YEAR---- NUM: 30000 UNIT: KWH</pre> | <p>This interface displays generated energy of that year. UP/DOWN button is invalid, and ENTER is also invalid; press ESC button to return back statistics interface (refer to 6.6).</p> |

6.6.8 Gross generation

| Interface | Explanation |
|--|---|
| <pre>----E-TOTAL---- NUM: 100000 UNIT: KWH</pre> | <p>This interface displays gross generation of the inverter. UP/DOWN button is invalid, and ENTER is also invalid; press ESC button to return back statistics interface (refer to 6.6).</p> |

07 Maintenance

Inverter does not require any regular maintenance. However, cleaning the dust on heat-sink will help the inverter to dissipate the heat and increase its life time. The dust can be removed with a soft brush.



CAUTION:

Do not touch the inverter's surface when it is operating. Some parts of the inverter may be hot and cause burns. Turn off the inverter and wait for a cool-down period before any maintenance or cleaning operation.



NOTE:

Never use any solvents, abrasives or corrosive materials to clean the inverter.

Fan Maintenance



DANGER:

- Stop the inverter and disconnect it from all power supplies before maintenance.
- Lethal voltage still exists in the inverter. Please wait for at least 5 minutes and then perform maintenance work.
- Only qualified electricians can maintain the fans.

Fans inside the inverter are used to cool the inverter during operation. If the fans do not operate normally, the inverter may not be cooled down and inverter efficiency may decrease. Therefore, it is necessary to clean the dirty fans and replace the broken fans in time.

The operation procedure is as follows:

Step 1: Stop the inverter;

Step 2: Unscrew the hand screw at the bottom of the fan side decoration and push down the decoration to complete the removal of the decoration;

Step 3: Press the hump of the latch hook, unplug the cable connection joint outwards;

Step 4: Pull out the fan module, clean the fans with soft brush or vacuum cleaner, and replace them when necessary;

Step 5: Reinstall the fan back to the inverter in reverse order and restart the inverter.

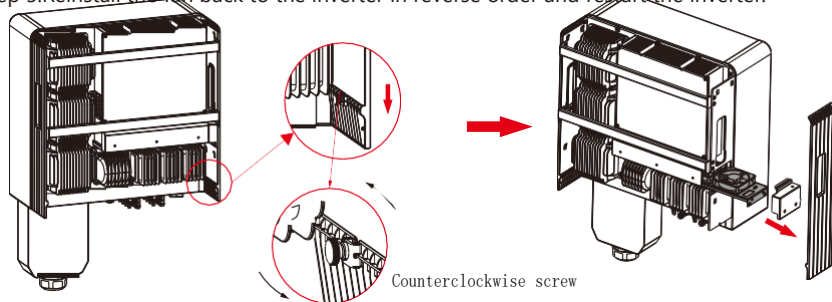

08 Trouble shooting

It is very easy for the inverter's maintenance. When you meet any problems, please refer to the following trouble shooting first, please contact your local distributor if the problem can't be solved by yourself.

The following sheet lists some basic questions may encounter in the operation.

| Alarm Message | Failure description | Solution |
|---------------|---|---|
| F00-F03 | AC voltage & frequency are too high or too low. | <ol style="list-style-type: none"> 1. Please check mains voltage whether it is complied with local, safety standard 2. Please check the AC output line is properly connected. Make sure its output voltage to see if it is normal. 3. Disconnect PV input and restart the inverter and check whether. 4. If the power grid is normal, the fault is still reported. Please contact the dealer. |
| F04-F05 | Bus voltage is too high or too low. | <ol style="list-style-type: none"> 1. Please check the setting of input mode 2. Disconnect PV input and restart the inverter and check whether fault still exists, Please contact the dealer. |
| F06 | Bus voltage is Unbalance | <ol style="list-style-type: none"> 1. Please check the setting of input mode. 2. Disconnect PV input and restart the inverter and check whether fault still exists. 3. The fault still exists after the restart. Please contact the dealer. |
| F07 | Insulation impedance Fault | <ol style="list-style-type: none"> 1. Disconnect PV input and restart the inverter and check whether fault still exists. 2. Please measure impedance of PV+ / PV- to ground whether is over than 50KΩ. 3. The insulation of the series is normal but the fault still exists. Please contact the dealer. |
| F08 | Input Current High | <ol style="list-style-type: none"> 1. Please check the setting of input mode. 2. Disconnect PV input and restart the inverter and check whether fault still exists. |
| F09 | Hardware Current High | <ol style="list-style-type: none"> 1. Disconnect PV input and restart the inverter after few minutes and check whether fault still exists. |
| F10 | Inverter Current High | <ol style="list-style-type: none"> 1. Disconnect PV input and restart the inverter after few minutes and check whether fault still exists. |

| Alarm Message | Failure description | Solution |
|---------------|---------------------------------------|---|
| F11 | Inverter DC Current high | 1.Disconnect PV input and restart the inverter after few minutes and check whether fault still exists. |
| F12 | Amb Temperature Over | 1.Disconnect PV input and cool down the inverter then restart the inverter to see if it is back to normal operation. 2.Please check environmental temperature whether out of working temperature. |
| F13 | Heatsink Temperature High | 1.Disconnect PV input and cool down the inverter then restart the inverter to see if it is back to normal operation. 2.Please check environmental temperature whether out of working temperature. |
| F14 | AC Relay Fault | 1.Disconnect PV input and restart the inverter and check whether fault still exists. 2. Check whether the phase line is missing phase, such as R, S, T phase. |
| F15 | PV Input Voltage Low | 1.Please check the configuration of PV input, one of PV input is idle when inverter is set on parallel mode. 2. Disconnect the PV input and restart the inverter and check whether fault still exists. |
| F16 | Remote Off | 1.The inverter is on remote OFF status, the Inverter can be turned,off/on remotely by monitoring software. |
| F18 | SPI communication Fault | 1.Disconnect PV input and restart the inverter and check whether fault still exists. |
| F20 | Leakage Current High | 1.Disconnect PV input and restart the inverter and check whether fault still exists. 2. Check whether the AC cable and PV input line have abnormal insulation. |
| F21 | Leakage Current Self-Checking Failure | 1.Disconnect PV input and restart the inverter and check whether fault still exists. 2. Contact with your local distributor if the fault still exists. |
| F22 | Consistency Voltage Fault | 1.Disconnect PV input and restart the inverter and check whether fault still exists. 2. Contact with your local distributor if the fault still exists. |

| Alarm Message | Failure description | Solution |
|---------------|---------------------------------|---|
| F23 | Consistency Frequency Fault | 1.Disconnect PV input and restart the inverter and check whether fault still exists. 2.Contact with your local distributor if the fault still exists. |
| F24 | DSP Operation Fault | 1.Disconnect PV input and restart the inverter and check whether fault still exists. 2.Contact with your local distributor if the fault still exists. |
| F26 | IGBT Fault | 1. Disconnect PV input and restart the inverter and check whether fault still exists. 2.Contact with your local distributor if the fault still exists. |
| F27 | N line-to-earth voltage is high | 1. Check whether the ground of the machine is connected to the ground of the power grid. 2. Check whether the voltage of line n to the ground is higher than the protection value. |
| F32 | DSP communication Lost | 1.Disconnect PV input and restart the inverter and check whether fault still exists. 2. Contact with your local distributor if the fault still exists. |

▲ Table 8.1 Trouble shooting



NOTE:

If the inverter displays any alarm message as listed in Table 8.1; please turn off the inverter (refer to Section 5.2 to stop your inverter) and wait for 5 minutes before restarting it (refer to Section 5.1 to start your inverter). If the failure persists, please contact your local distributor or the service center. Please keep ready with you the following information before contacting us.

1. Serial number of Inverter;
2. The distributor/dealer of Inverter (if available);
3. Installation date.
4. The description of problem (i.e. the alarm message displayed on the LCD and the status of the LED status indicator lights. Other readings obtained from the Information submenu will also be helpful.) ;
5. The PV array configuration (e.g. number of panels, capacity of panels, number of strings ,etc.);
6. Your contact details.

